

# NKNWD PUBLIC MEETING

April 11, 2026

## COMMISSIONERS

- Barbara Rippey, Secretary
- Mark Roberts
- Craig Nern
- Bruce Rudd
- David Boone, President

## EMPLOYEES

- Thia Pierson, Business Office Manager
- Coren Tradd, Operator Trainee

# MEETING TOPICS

- General Update
- District Financials
- Base Rate Changes
- Water Use Rate Changes
- Capital Improvements: Current and Future
- Wrap Up

# DISTRICT UPDATES

1. New District Employees
2. Remote Reading Water Meters
3. On Demand Generators
4. New SCADA System
5. Acquired Lot On HWY 101—Protecting Watershed
6. Check District's Website ([nknwd.org](http://nknwd.org))

# DISTRICT STATS

- WATER SOURCE: 4 SPRINGS
- CURRENTLY 402 HOOKUPS
- CUSTOMERS
  - ABOUT 100 FULL TIME OCCUPIED RESIDENCES
  - ABOUT 211 PART TIME OCCUPIED RESIDENCES
  - 2 LICENSED RESIDENT OCCUPIED RENTALS
  - 82 LICENSED SHORT-TERM RENTALS (86 ALLOWED)
- BILLED 10MM GALLONS IN 2025

# WATER SYSTEM OVERVIEW

## ANNOTATED SYSTEM DIAGRAM 01

psl 8/27/2025, file: CW1a.vsd  
 from Civil West report *Neahkahnie Water District Water Storage Evaluation*  
 (by Tim Gross, 5/16/2025, file: *Neahkahnie Storage Evaluation 5-7-25.pdf*)

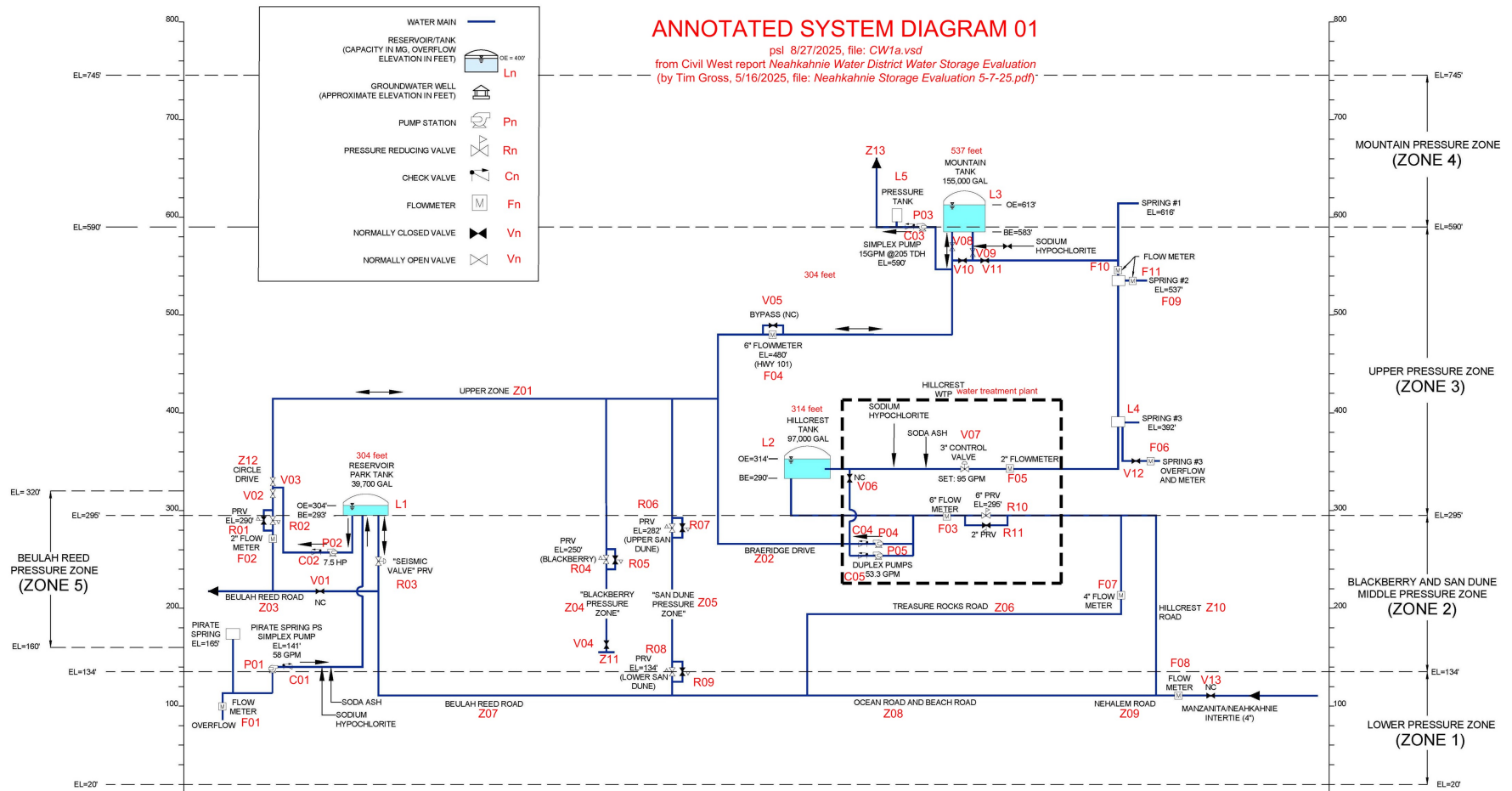



# WATER BILL

METER READ	01/04/2026 64609	03/03/2026 68571	USAGE [ ]
------------	---------------------	---------------------	--------------

Prior Balance  
Payment(s)  
Water  
Capital Improvement  
Watershed Protection Debt Fee  
Base Fee

[ ]

DUE DATE	[ ]	AMT DUE	[ ]
ACCT NO.	[ ]	IF LATE	[ ]
BILL DATE	[ ]	SRV TYPE	<b>Residential</b>
SERVICE ADDRESS [ ]			
DUE DATE	[ ]	AMT DUE	[ ]

This account is enrolled in AUTOPAY

<b>Total Due</b>		[ ]	
DUE DATE	[ ]	IF LATE	[ ]

RETURN THIS STUB WITH PAYMENT.

**ALERT: A \$25 LATE FEE WILL APPLY TO BILLS PAST DUE!  
AND FOR EACH MONTH THEREAFTER!**

# HOW YOU CAN HELP THE DISTRICT

- GET YOUR BILLS BY EMAIL
- USE AUTO-PAY
- PROVIDE CURRENT / EMERGENCY CONTACT INFORMATION
- KEEP YOUR WATER METERS ACCESSIBLE

# CHALLENGES

- Operating Revenue vs Operating Expenses
- Aging Infrastructure = Equipment Replacements & Improvements Needed
- Increasing Demand = Capital Improvements
- 402 Hookups = No Economy of Scale
- Summer Water Supply vs Summer Demand

# LET'S TALK \$\$\$\$\$

## 2025-2026 Budget

### DISTRICT REVENUE SOURCES

1. TAX LEVY : \$ 165K
2. BASE RATE: \$ 196K                      **Total: \$ 421K**
3. WATER USE: \$ 60K

### OPERATING COSTS

1. EMPLOYEE SALARIES & BENEFITS: \$200K                      **Total: \$ 415K**
2. MATERIALS & SERVICES: \$215K

# IN AN IDEAL OPERATION

- WATER USE REVENUE PAYS FOR MOST OF OPERATIONS
- BASE RATE PAYS PARTLY FOR OPERATIONS PLUS SYSTEM CAPITAL REPAIRS
- TAX LEVY PAYS FOR CAPITAL NEEDS

PAYING ALL OPERATIONS WITH WATER USE = \$42 / 1000 GALLONS

## BASE RATE HISTORY

- \$25 Per Month Established In 2007. No Inflation Adjustment.
- Increased to \$40 Effective January 2025
- Inflation Adjustment of \$1.88 Effective January 2026
- If Inflation Rate For Water System Maintenance Had Been Applied Since 2007 = \$ 60 in Jan 2026

# PROPOSED BASE RATE INCREASE

- **EFFECTIVE JULY 1, 2026**
- BASE RATE WILL INCREASE BY **\$10 PER MONTH TO \$51.88.**
- **TWO MONTH BILL** WILL INCREASE \$20 FROM \$83.76 TO **\$103.76**
- INCREASE TOTAL DISTRICT REVENUE BY ABOUT \$48,000/YEAR
- START PLACING SOME OF TAX REVENUE IN CAPITAL IMPROVEMENT ACCOUNT

# QUESTIONS

# NWD Public Meeting

## Water Use Rates

1. The Neahkahnie Water District ( a non-profit special district) serves 400+ households from four springs on Neahkahnie Mountain.
2. Our water bills include:
  - a fixed system charge for land and significant equipment purchases (61% of total bill),
  - a base fee that covers 30% of bill; and
  - water use rates that pay for the balance (9%) of remaining bill.
3. Our goal with water use rates is to help cover operating costs while ensuring a sufficient supply of water to our community year-round.
4. Water use rates can help align demand with supply by more strongly promoting the conservation of water.
  - Higher water use = higher water bill
  - Highest water use = highest \$/gallon rate via four rate levels
5. We are proposing increasing the water use rates in two ways:
  - 1 – Water use levels narrowed
  - 2 - Water use rate for each level is increased- slightly for low water users, more for high water users.

# Water Use Varies Widely

(July + August 2025 actual use)

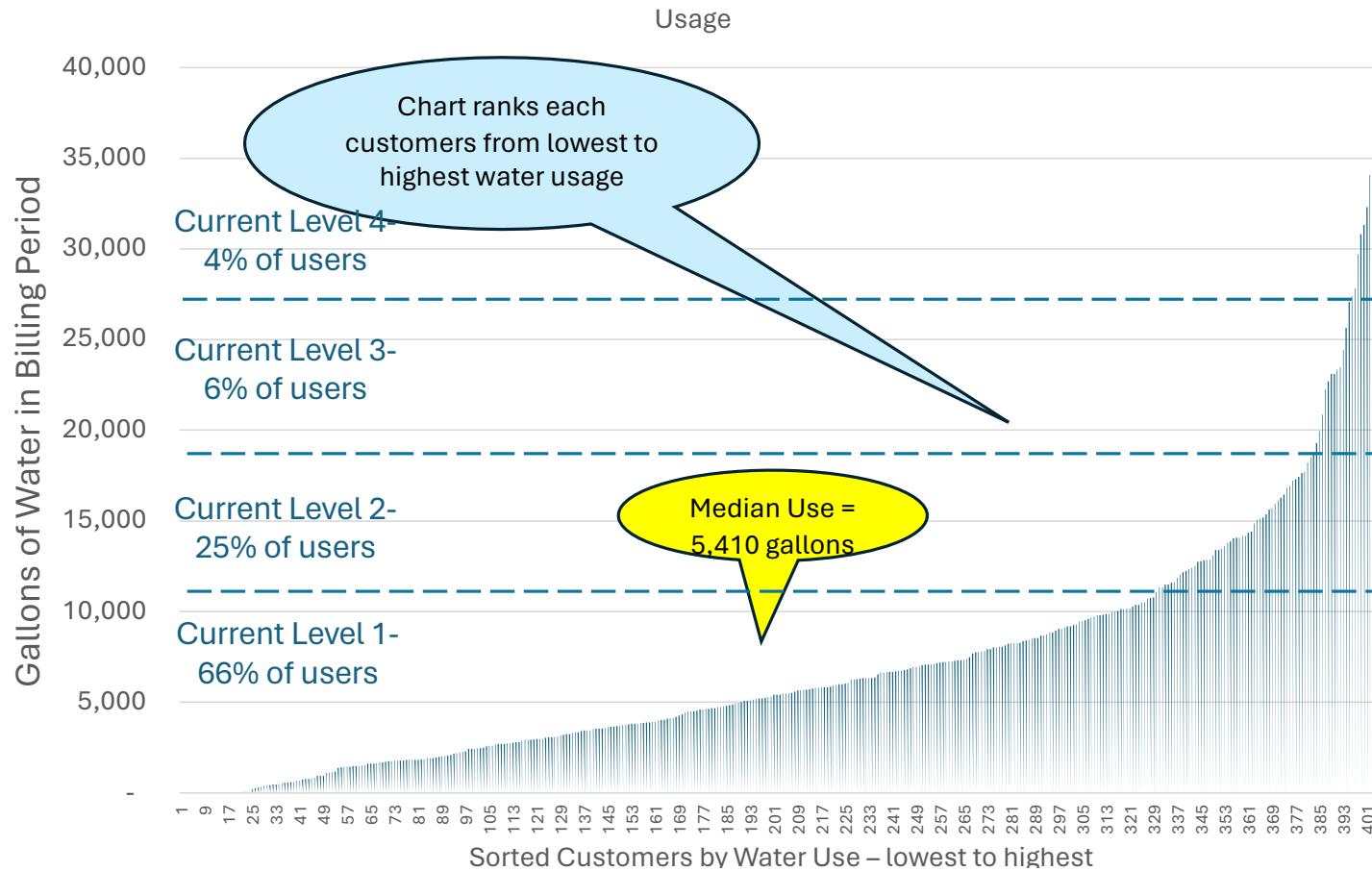

# Reducing size of water use levels

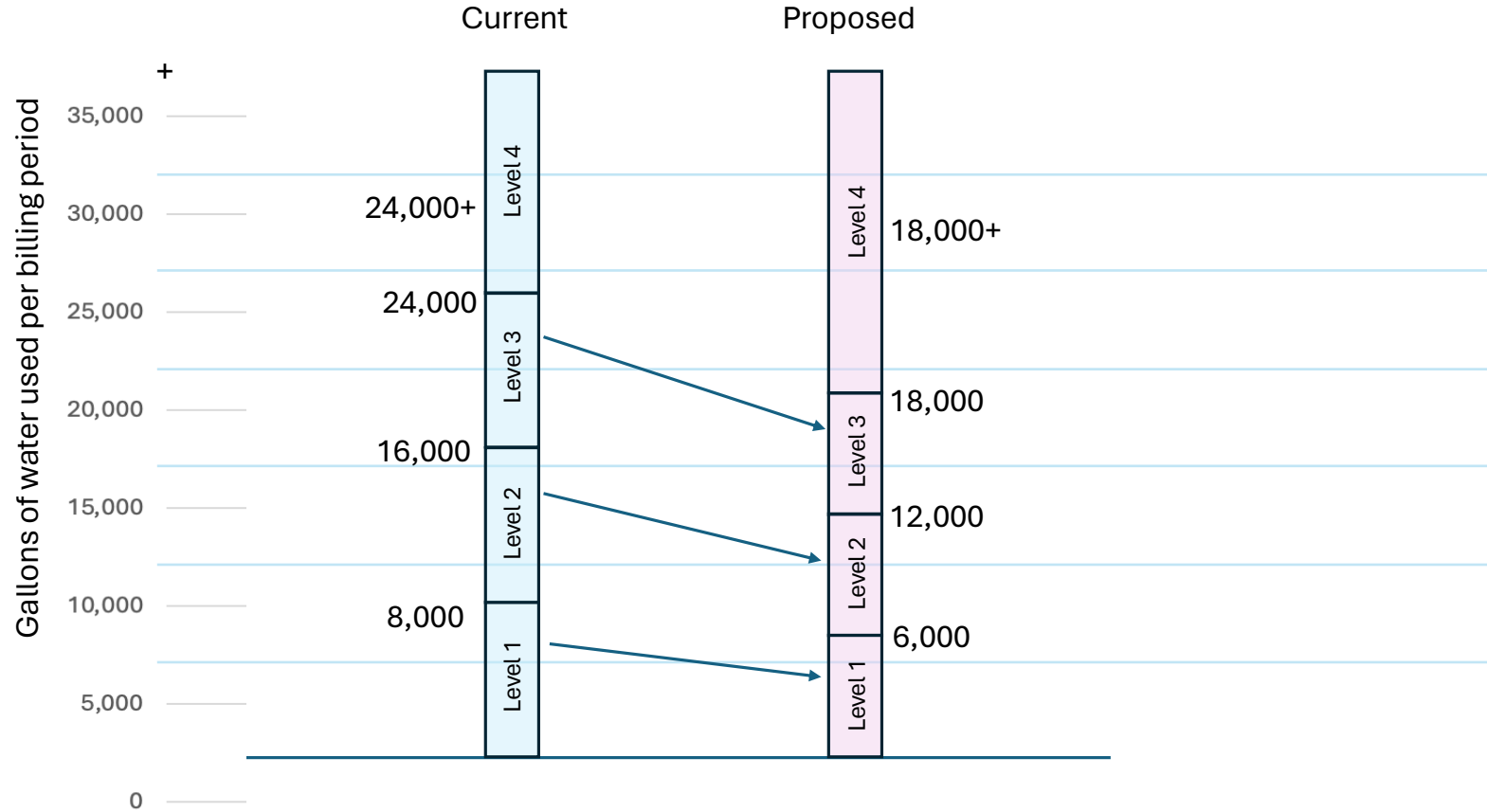

# Water Use Varies Widely

(July + August 2025 actual use)

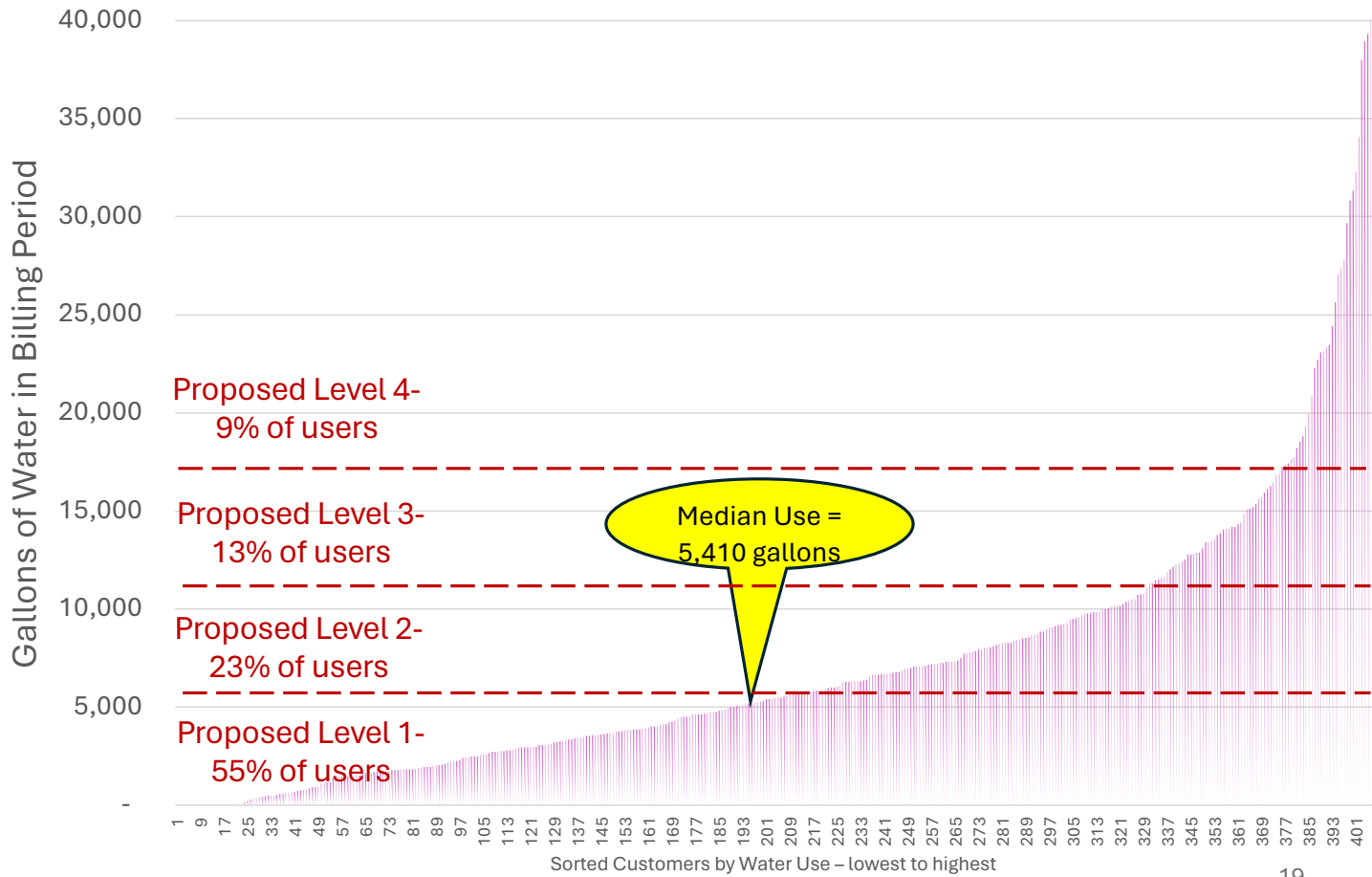

# Water Use by Level

(July/August 2025)

Median Use per Customer

Number of Customers

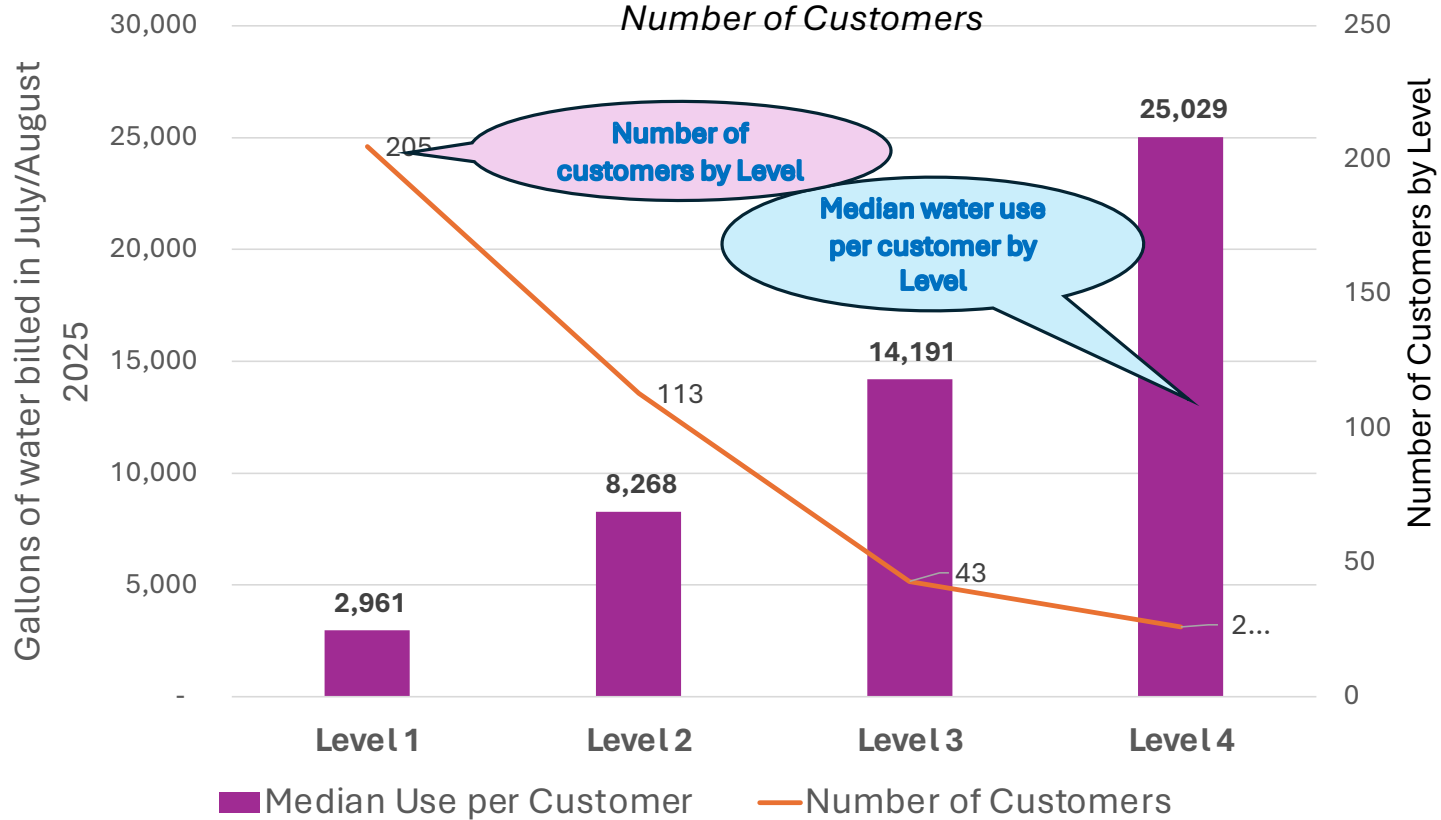

# Adding seasonal rates & increasing use rates

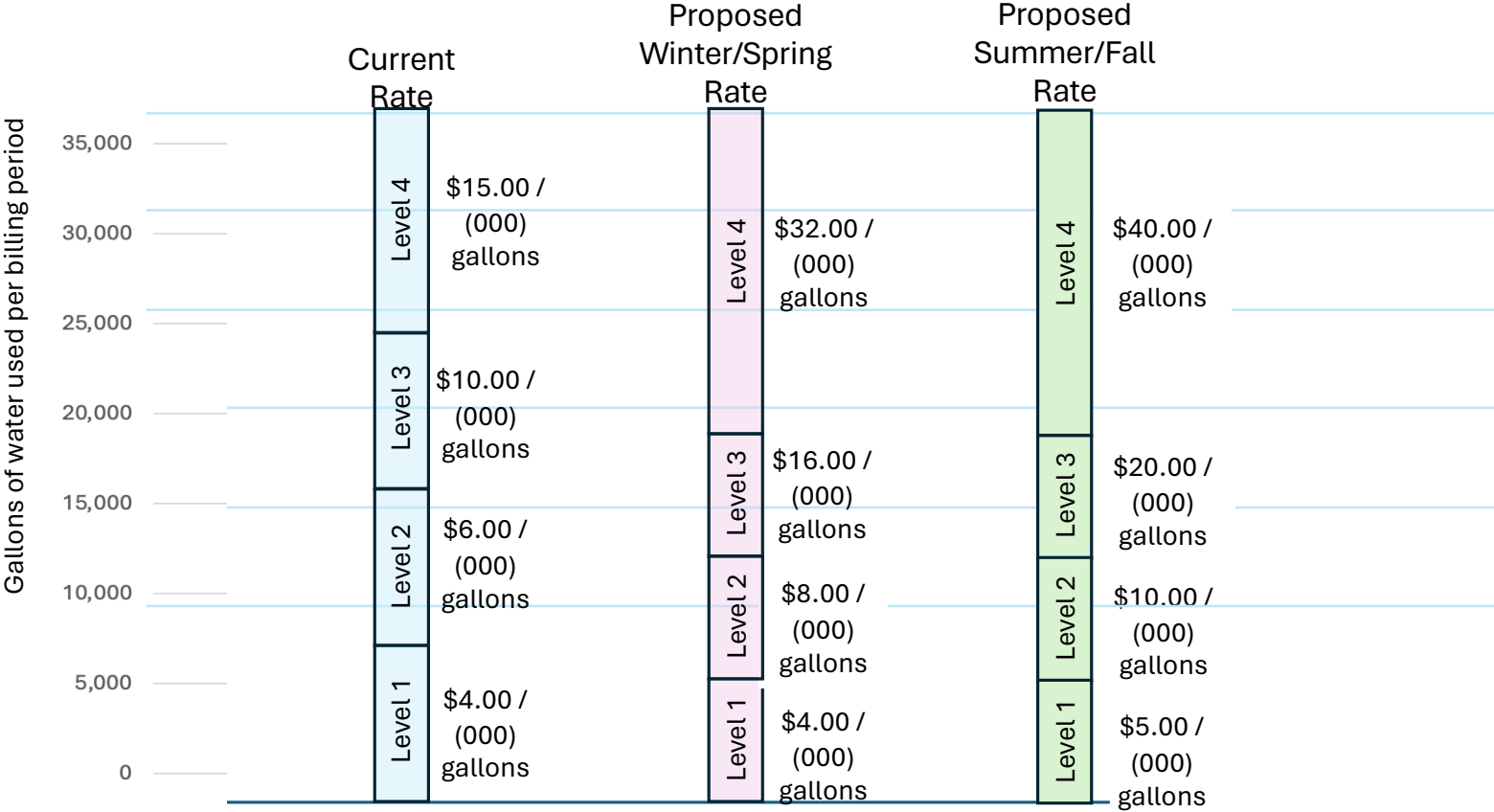

# Median<sup>#</sup> July/August Water Bill

(Two-month billing period; based on median use)

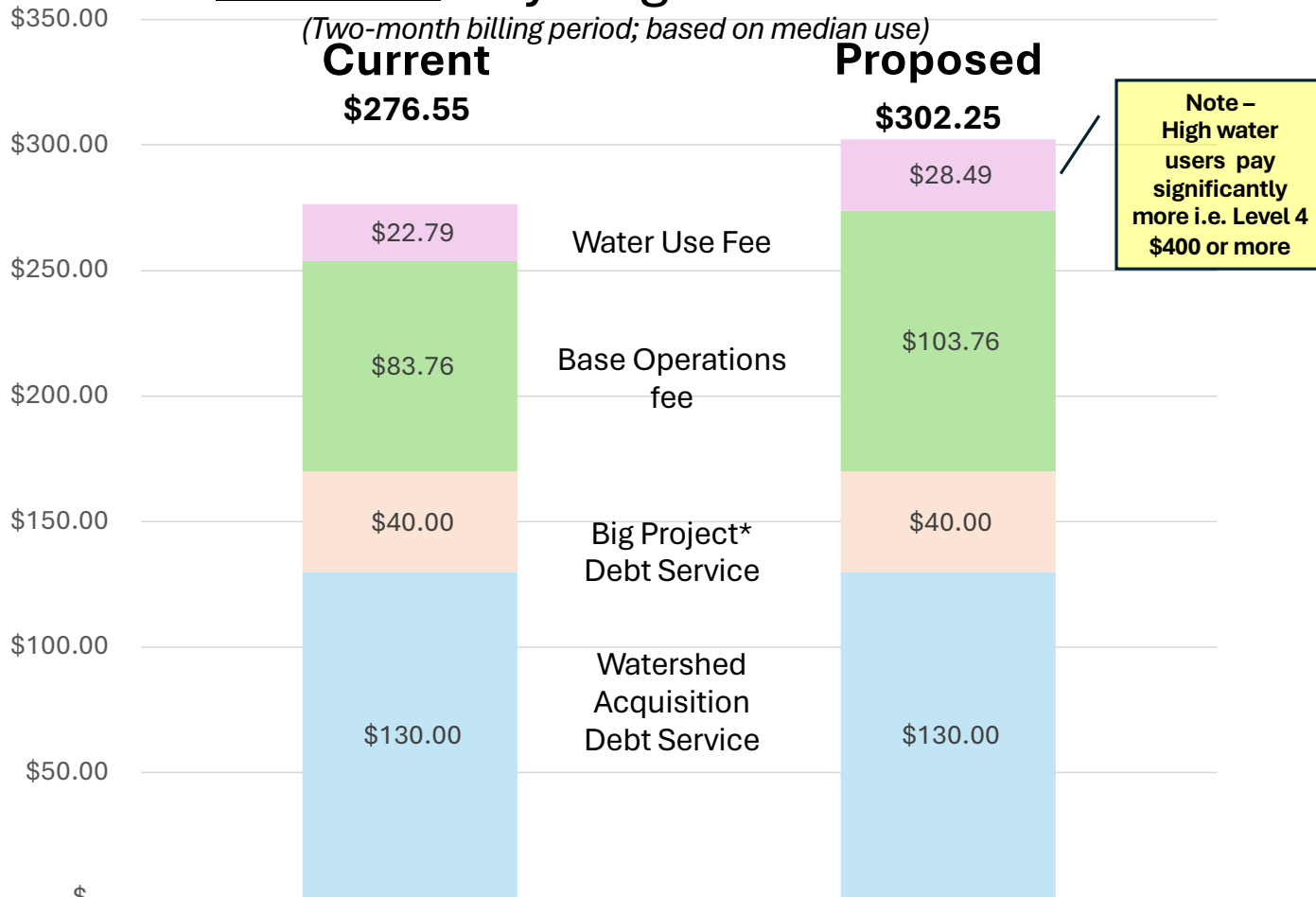

**Note – High water users pay significantly more i.e. Level 4 \$400 or more**

# - Median use July/August 2025 = 5,410 gallons

\* - Big Project Debt Service originated in 2006. Financed Mountain Tank, new 6" water mains, and new fire hydrants

# Median# November/December Water Bill

(Two-month billing period; based on median use)

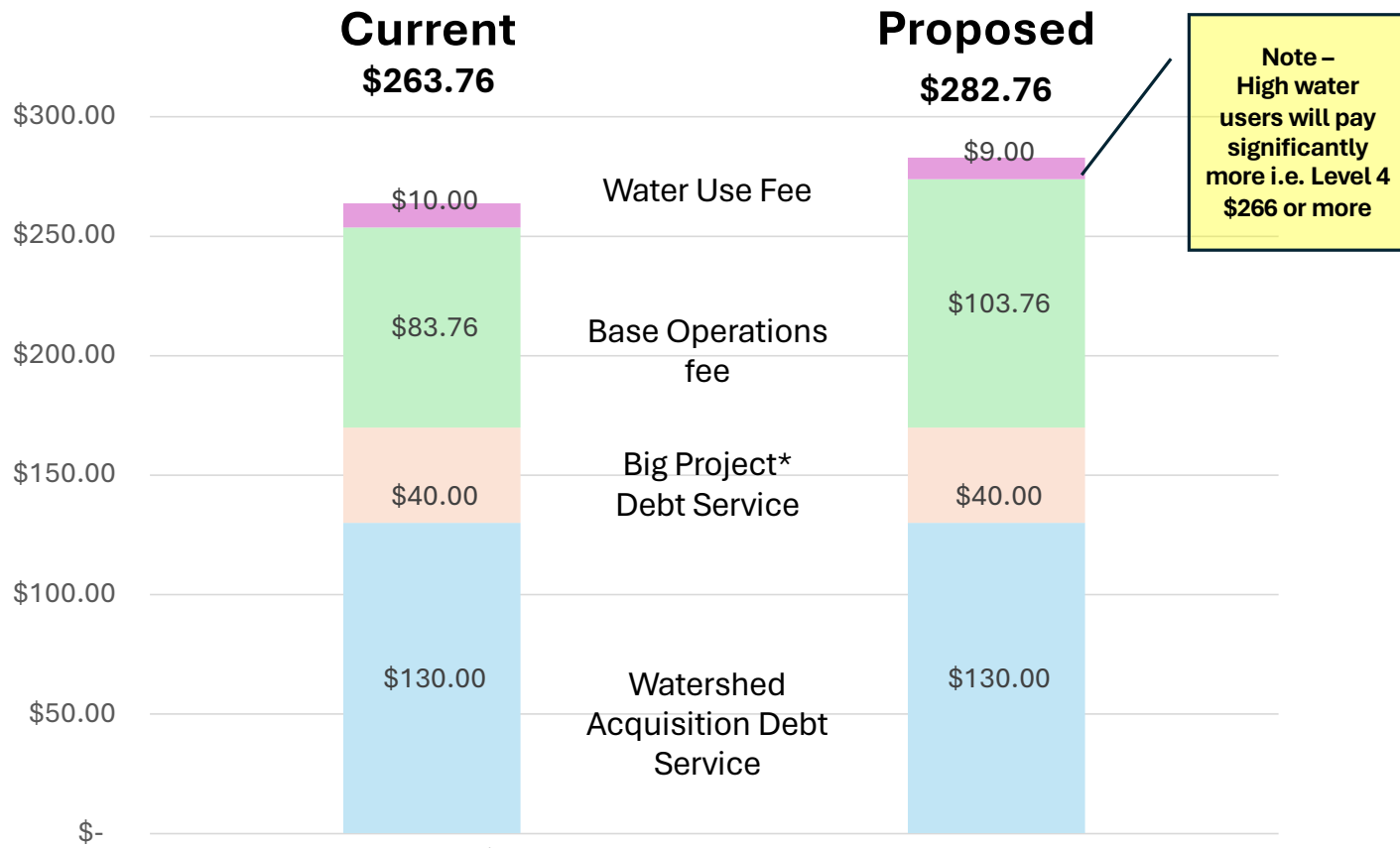

# - Median use Nov/Dec 2025 = 2,324 gallons

\* - Big Project Debt Service originated in 2006. Financed Mountain Tank, new 6" water mains, and new fire hydrants

Questions?

## *Capital Improvements*

Working toward strong infrastructure

April 11, 202



## *Neahkahnie drinking water - early days*



*Hillcrest  
Tank*

# *Mountain Tank*



April 26

28

## *System Components*

➤ Storage Tanks	\$\$\$\$
➤ Spring Catchments	\$\$\$
➤ Pumps & Valves	\$\$\$
➤ Mains & Lines	\$\$\$
➤ Control/Monitoring	\$\$\$
➤ Treatment Equipment	\$\$
➤ Fire Hydrants	\$\$
➤ Intertie - Manzanita	??

# *Priorities*

- Hillcrest Tank rehab
- Replacement of critical pumps
- Replacement of key system flow meters
- Possible intertie with City of Manzanita
- Major new storage tank

# *Funding Sources*

- Water user rates and fees
- Property tax levies
- Special assessments
- State and Federal Grants
- Loans
- Bond issuance